

6.3

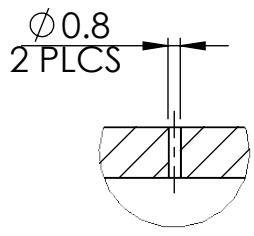

DETAIL A
SCALE 2 : 1

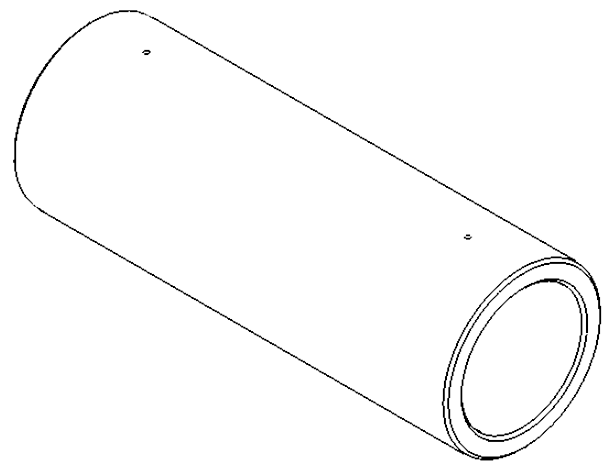

1. * Dimensions for reference
2. Quantity for 1 set: 2 pcs
3. Unless otherwise specified:
 1. dimensions are in mm
 2. surface finish: 6.3
 3. tolerances:
 - linear: ± 0.1 mm
 - angular: $\pm 0.1^\circ$
4. Remove burrs and sharp edges
5. Cleaning of manufactured parts must be implemented in accordance with the present step-by-step instruction for cleaning parts after tooling

| | | | | | | | | | | | | |
|--|--|--|---------|--|------------------------------------|--|----------------------|--|---------------------|--|--------------|--|
| UNLESS OTHERWISE SPECIFIED: DIMENSIONS ARE IN MILLIMETERS SURFACE FINISH: 6.3 TOLERANCES: LINEAR: ± 0.1 mm ANGULAR: $\pm 0.1^\circ$ | | | FINISH: | | DEBURR AND BREAK SHARP EDGES | | DO NOT SCALE DRAWING | | REVISION 3 | | | |
| | | | | | | | Interlab | | | | | |
| | | | | | | | Coil body | | | | | |
| | | | | | | | MATERIAL: | | DWG NO. | | A4 | |
| | | | | | | | FR4 Tube | | 1501.01.03.05_rev.3 | | | |
| | | | | | | | WEIGHT: | | SCALE:1:1 | | SHEET 1 OF 1 | |

| | NAME | SIGNATURE | DATE |
|--------|-------------|-----------|----------|
| DRAWN | A. Nikolaev | | 14.11.19 |
| CHK'D | N. Nikolaev | | 14.11.19 |
| APPV'D | I. Garipov | | 14.11.19 |
| MFG | | | |
| Q.A | | | |
| | | | |
| | | | |
| | | | |

| | |
|---------------------|--|
| TITLE: | |
| Coil body | |
| DWG NO. | |
| 1501.01.03.05_rev.3 | |
| A4 | |
| SCALE:1:1 | |
| SHEET 1 OF 1 | |